



SMS IP: high voltage sealed plastic connector

A connector designed for indoor railway equipments, using the standard Ø 1.6 contact.

Safe ■ Finger proof
High operating voltage up to 500 V

Compliant to fire and smoke standards ■ EN 45-545 - HL3/R22 - HL3/R23
NF F 16-101/16-102 - I3F2

Sealed ■ IP66 & IP67

Easy to handle ■ 1 stainless steel latch

Design for railways ■ NF F 61-030 derivated
Tested according to EN 50 467



Technical Features



Mechanical

- **Durability:** 500 mating/unmating
- **Vibrations & shocks:** EN 61-373 Cat.2
- **Locking system:** 1 metallic latch - Audible "Click"
- **Keying system:** up to 3 different positions

Electrical

- **Current rating per contact:** 15 A maxi
- **Operating voltage:** ≤ 500 Vdc / ≤ 380 Vac following NF F 61-030
500 Vdc/ac following EN 50-124-1 - OV2 PD3
- **Creepage distances (unmated):** > 12 mm
- **Clearance distances (unmated):** > 8 mm
- **Withstanding voltage:** 3250 V
- **Insulation resistance:** ≥ 5000 MΩ
- **Contacts resistance:** ≤ 2.5 mΩ

Material

- **Plug & receptacle:** black thermoplastic
- **Grommet & interfacial seal:** light grey silicone
- **Latch:** stainless steel

Environmental

- **Fire resistance, toxicity & smoke opacity:**
HL3/R22 - HL3/R23 following EN 45 545
I3/F2 following NF F 16-101
- **RoHS:** compliant
- **Damp heat:** 21 days / 40°C / 95% RH
- **Operating temperature:** -50°C to +100°C
- **Resistance to fluids:** gas oil, mineral oil, acid bath, oxalic acid
- **Corrosion:** 500 hours salt spray resistant

Sealed version (SMS IP67)

- **Sealing:** IP66 & IP67 - Following CEI 60-529
- Delivered with pre-mounted grommets and interfacial seal
- IP rating is ensured if the grommets are in their cavities.

Ordering information

SMS IP SERIES	SMS	3	P	IP67	-
Contact layout: 3 – 6 – 12					
Contact type: P: Plug for female contacts R: Receptacle for male contacts					
Application: IP67: Sealed version IP20: Non sealed version - delivered without grommet					
Contacts: -: Without contact K01: With contacts RM16M23K or RC16M23K K02: With contacts RM14M23K or RC14M23K					

Contacts

- Standard crimp machined contact #16 compatible with EN 50-306-2 & EN 50-264-3-1 wires

Contact size	Type	Wire size			Part number		Mini insulator Ø mm	Max insulator Ø mm
		AWG	mm2	Max wire Ø mm	Male	Female		
#16 Ø 1.6 mm	Machined	20-16	0.5-1.5	1.8	RM16M23K	RC16M23K	1.15	3.8
		16-14	1.5-2.5	2.28	RM14M30K	RC14M30K	1.15	3.8

For other contact type consult us

Dimensions & weight

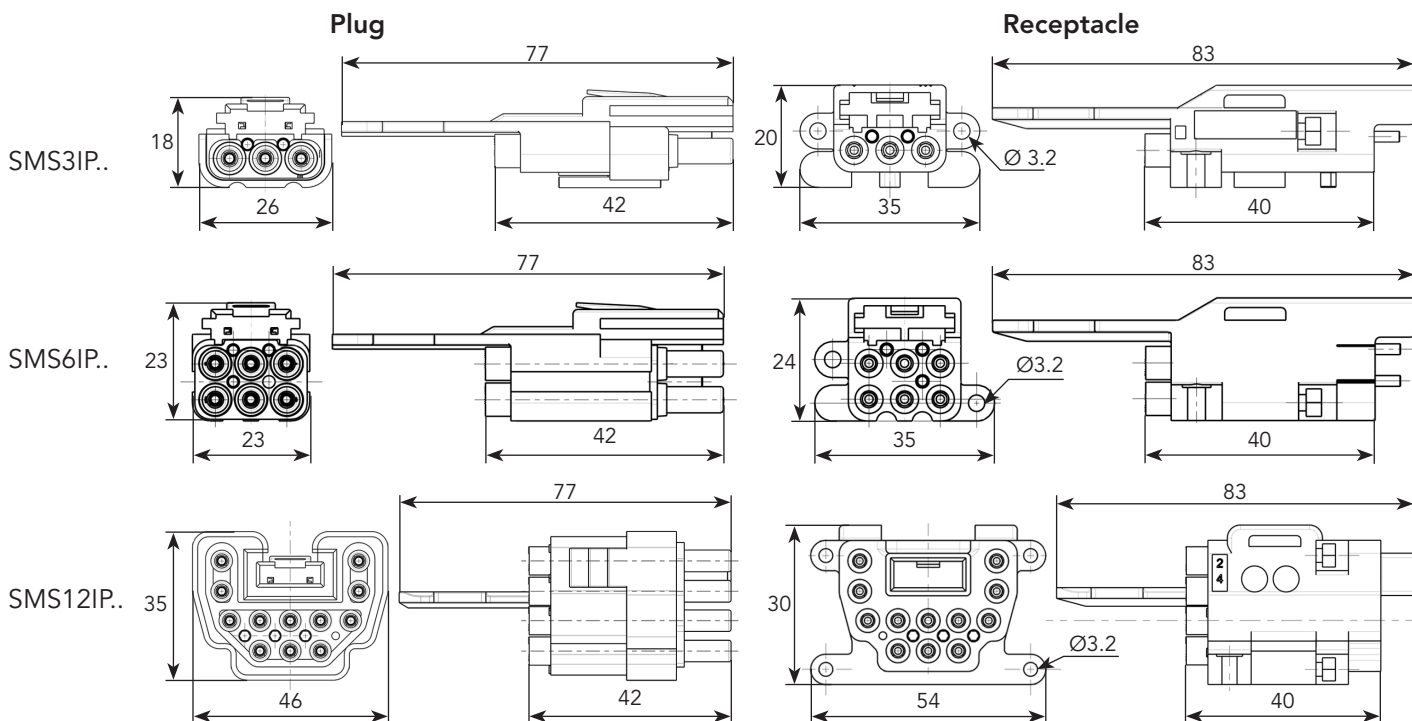

Part number - Plug		Layout	Weight * ±0.2 g.
Without contact	With contacts ⁽¹⁾		
SMS3PIP20	SMS3PIP20K01 SMS3PIP20K02	3	13.3 g
SMS3PIP67	SMS3PIP67K01 SMS3PIP67K02		
SMS6PIP20	SMS6PIP20K01 SMS6PIP20K02	6	16.3 g
SMS6PIP67	SMS6PIP67K01 SMS6PIP67K02		
SMS12PIP20	SMS12PIP20K01 SMS12PIP20K02	12	40 g
SMS12PIP67	SMS12PIP67K01 SMS12PIP67K02		

Part number - Receptacle			Layout	Weight * ±0.2 g.
Without contact	With contacts ⁽¹⁾			
SMS3RIP20	SMS3RIP20K01	SMS3RIP20K02	3	16.4 g
SMS3RIP67	SMS3RIP67K01	SMS3RIP67K02		
SMS6RIP20	SMS6RIP20K01	SMS6RIP20K02	6	20.3 g
SMS6RIP67	SMS6RIP67K01	SMS6RIP67K02		
SMS12RIP20	SMS12RIP20K01	SMS12RIP20K02	12	48 g
SMS12RIP67	SMS12RIP67K01	SMS12RIP67K02		

* weight of the connector without contact 1: see page 2 «Ordering information» Matrix

Panel cut out

	A	B	C	D	E	F	Ø G
SMS3RIP..	28.2	18.3	23.3	12.5	9.6	9.6	3.2
SMS6RIP..	28.2	25.1	23.3	12.5	8.5	4	3.2
SMS12RIP..	47.4	31.4	42.5	12.5	26.3	4	3.2

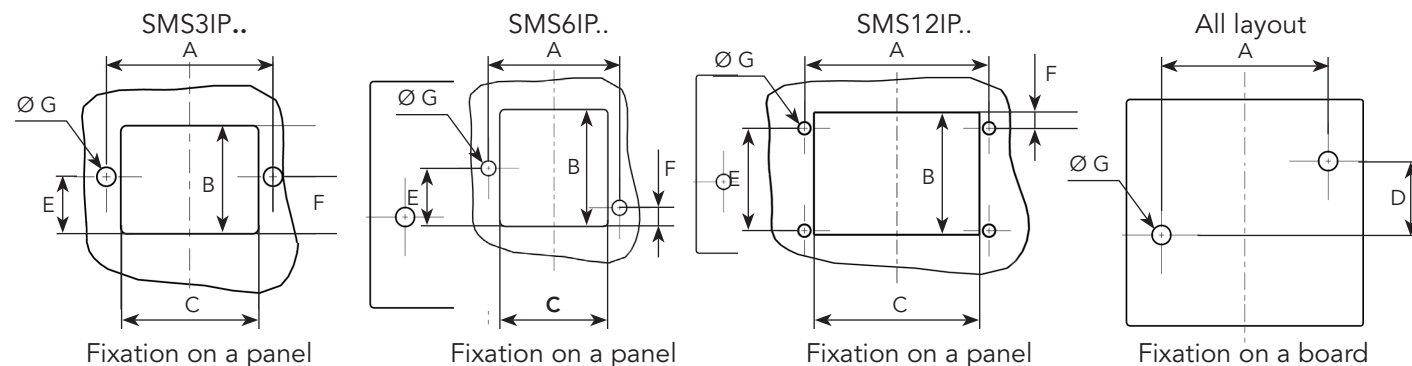

Note : all dimensions are in mm

Assembly instructions

Crimp contacts on wires

- Strip each wire to the indicated length.



Crimping tools



Manual crimp pliers	Locator	Selector set-up - Wire section				
MH860 (M22520/7-01)	MH86164G or TP1142	6 0.5 mm ²	7 0.75 mm ²	7 1 mm ²	8 1.5 mm ²	-
FT8	-	4 0.5 mm ²	4 0.75 mm ²	5 1 mm ²	5 1.5 mm ²	-
AF8 (M22520/1-01)	TP1142	-	-	-	-	8 2.5 mm ²

Following standard: EN 50306-2

Following standard: EN 50264-3-1

Contact insertion

- Locate the right cavity and use a contact (male or female), to bore each individual grommet in its center. Push the contact until mechanical stop.



- Check the correct contact retention by slightly pulling on the cable (no tools required).
- Check that each individual grommet is correctly plated on the back face of the connector, unless, put them properly.

Once all the contacts have been installed in the connector:

- Put the ty-rap in the designated cable support and tighten the ty-rap to gather the wires.

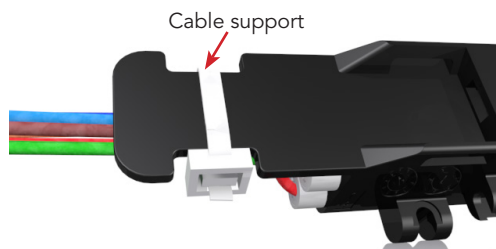

Receptacle coding

Connectors are supplied with coding pins, ensure to remove these pins before using the connectors.

- Coding is done by 1 or 2 pins depending on the layout (see page 7).

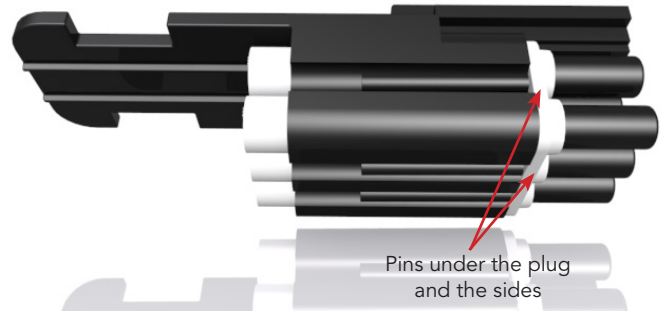
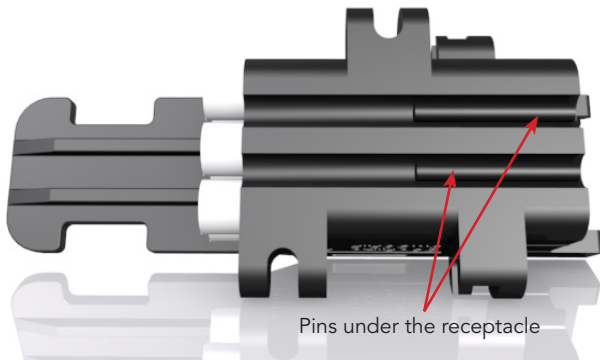

- Pre-locate the pin into the correct cavity depending on the chosen coding (see Coding configuration).

Receptacle

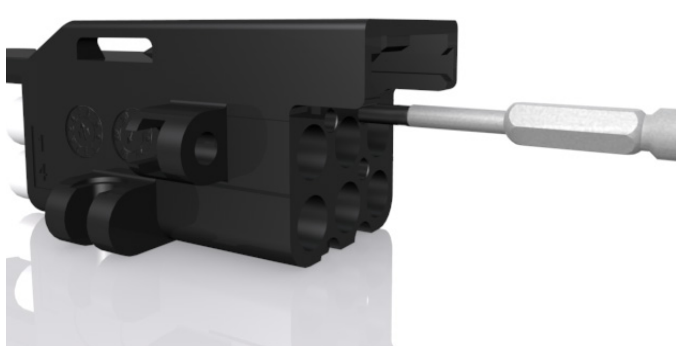

- Push the pin with the contact insertion tool (RX2025GE1) until mechanical stop. The outside height must be 5mm maxi.

Plug

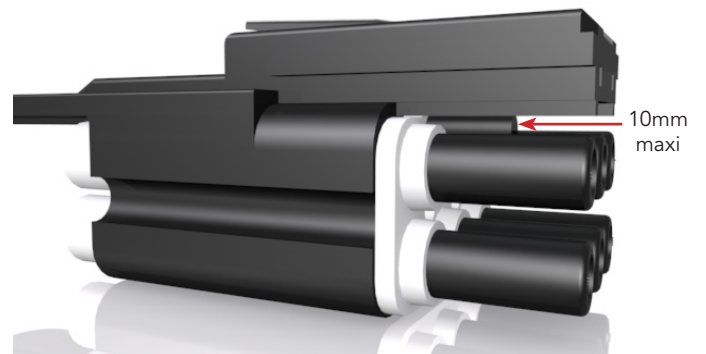
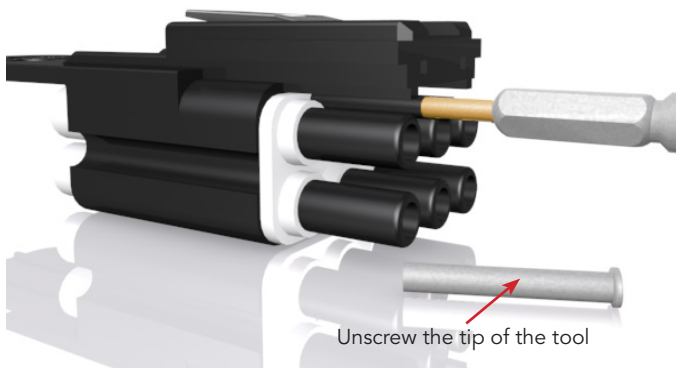

- Push the pin with the contact insertion tool (RX2025GE1) without its tip until mechanical stop. The outside height must be 10mm maxi.

Coding configuration

Layout 3

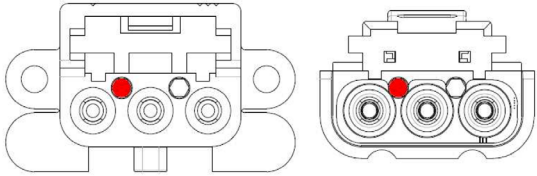

Coding A

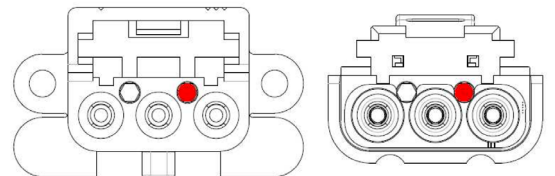

Coding B

Layout 6

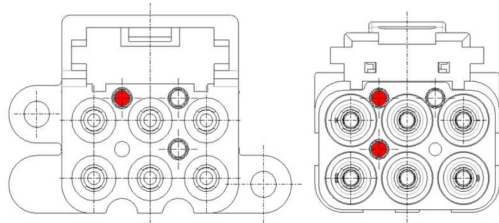

Coding A

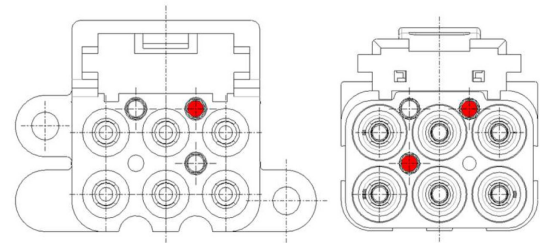

Coding B

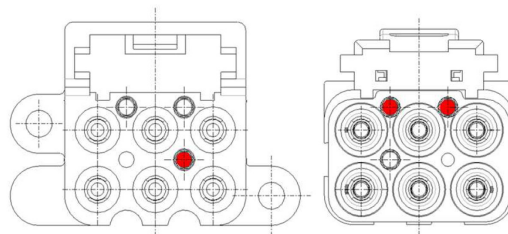

Coding C

Layout 12

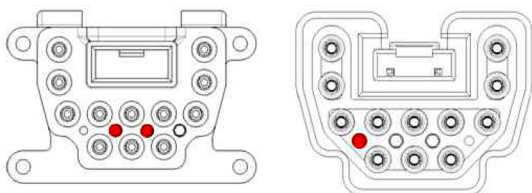

Coding A

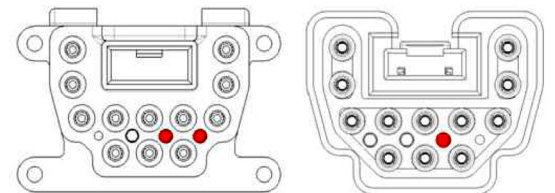

Coding B

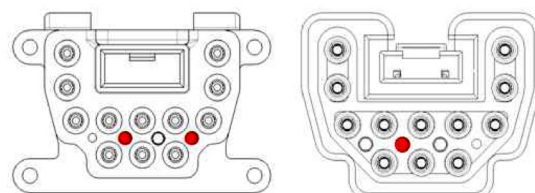

Coding C

Fixing the connectors

Rear panel mount fixing (Panel cut out dimensions page 4)

- Initially place the nut in its cavity. The nut must be placed correctly so that it cannot turn in its cavity.

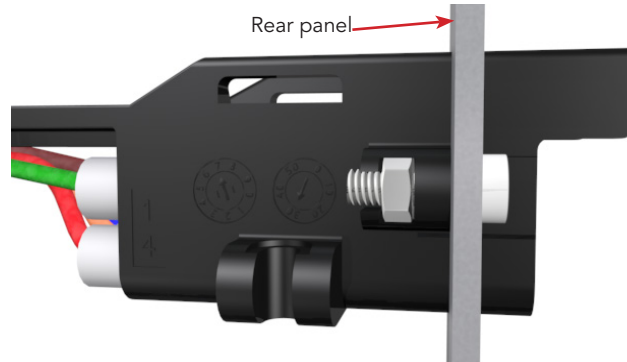

- Introduce the receptacle by the rear panel and tighten the 2 screws (washers can be added). The recommended tightening torque is: 1.7N.m maxi with M3 stainless steel screws.

Flat board receptacle fixing (Fixation points defined page 4)

- Place the receptacle on the flat board and tighten the 2 screws (washer can be added). The recommended tightening torque is: 1.7N.m maxi with M3 stainless steel.



*For layout 6 cavities: In the particular case on using the connector at a working voltage higher than 220V along with a fixing on a conductive flat board, it will be necessary to insulate the board in order to meet the clearance and creepage distances given in the NFF61-030 standard.

Fixing by ty-rap

- Put the ty-rap through the 2 flat cable supports and tighten the receptacle against its panel (The locking system side should not be against the panel in order to keep the possibility to unmate the plug easily).

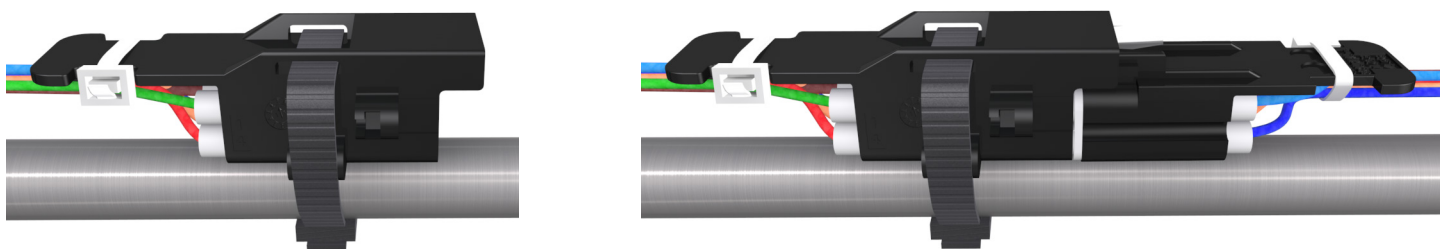

Mated pair

SOURIAU

souriau-industrial.com

contactindustry@souriau.com

